



 **Raccordi ad innesto rapido in polimero (nero)**

 Plastic push-in fittings (black)

 Steckverschraubungen Kunststoff (schwarz)

 Raccords instantanés polymère (noir)

 Racordaje automático en tecnopolimero (negro)

RP51K



RP51TK



RP51



RP52



RP53



RP54



RP55



RP58



RP59



RP60



RP61



RP62



RP65



RP65F



RP70K



RP70



RP71K



RP71



RP72K



RP72



RP72KP



RP72P



RP72F



RP45



RP73



RP91



RP74K



RP74



RP75



RP76



RP83K



RP83



RP84K



RP85



RP88



RP89



Dati tecnici dei raccordi ad innesto rapido in polimero (nero)

 Plastic push-in fittings (black) technical data

 Technischen Daten der Steckverschraubungen Kunststoff (schwarz)

 Données techniques des raccords instantanés polymère (noir)

 Datos técnicos de los racordaje automático en tecnopolimero (negro)

Caratteristiche principali

1. Innesto e disinnesco rapido
2. Filettatura BSPP cilindrica UNI-ISO228 - ISO16030 con O-Ring, BSPT conica UNI-ISO 7 teflonata, Metrica ISO/R 262
3. Guarnizione in NBR Silicon free
4. Portata piena rispetto al tubo utilizzato
5. Vasta gamma

Main features

1. Quick coupling and uncoupling
2. Threading BSPP cylindrical UNI-ISO228 - ISO16030 with O-Ring, BSPT conical teflon-coated UNI-ISO 7, ISO/R 262 metric
3. Silicon free NBR seal
4. Full flow to the tube used
5. Wide range

Hauptmerkmale

1. Schnelles Ein- und Auskuppeln
2. BSPP zylindrisches Gewinde UNI-ISO228 - ISO16030 mit O-Ring, teflonbeschichtet UNI-ISO 7 BSPT, metrische ISO/R 262
3. Silikonfreie NBR-Dichtung
4. Voller Durchfluss im Vergleich zu dem verwendeten Schlauch
5. Große Auswahl

Principales caractéristiques

1. Accouplement et découplage rapide
2. Filetage BSPP cylindrique UNI-ISO228 - ISO16030 avec joint torique, BSPT conique UNI-ISO 7 avec téflon, ISO/R 262 métrique
3. Garniture NBR sans silicone
4. Plein débit au tube utilise
5. Large gamme

Características principales

1. Acoplamiento y desacoplamiento rápido
2. Roscado BSPP cilíndrica UNI-ISO228 - ISO16030 con junta tórica, BSPT cónica UNI-ISO 7 con teflón, métrica ISO/R 262
3. Guarnición en NBR sin silicona
4. Caudal completo hacia el tubo utilizado
5. Amplia gama

Applicazioni

1. Robotica - Meccatronica
2. Impianti per automazione pneumatica
3. Industria del packaging
4. Industria tessile
5. Automotive
6. Vuoto

Applications

1. Robotics - Mechatronics
2. Systems for pneumatic automation
3. Packaging industry
4. Textile industry
5. Automotive
6. Vacuum

Anwendungen





1. Robotik - Mechatronik
2. Systeme für die pneumatische Automatisierung
3. Verpackungsindustrie
4. Textilindustrie
5. Automobil
6. Leer

Applications

1. Robotique - Mécatronique
2. Installations pour l'automatisation pneumatique
3. Industrie de l'emballage
4. Industrie textile
5. Industrie automobile
6. Vide

Aplicaciones

1. Robótica - Mecatrónica
2. Instalaciones para automatización neumática
3. Industria de embalaje
4. Industria textil
5. Industria automoción
6. Vacío

 Materiali	 Materials	 Werkstoffen	 Matériels	 Materiales
Corpo: Ottone nichelato CW614N o resina acetilica	Body: Nickel plated brass CW614N or acetal resin	Körper: vernickelt Messing CW614N oder acetalharz	Corps: Laiton nickelé CW614N ou résine acétale	Cuerpo: Latón niquelado CW614N o resina acetal
Pulsante: Resina acetilica	Sleeve: Acetal resin	Taste: Acetalharz	Bouton: Résine acétale	Pulsador: Resina acetal
Distanziale: Zinco	Spacer ring: Zinc	Distanzring: Zink	Rondelle d'épaisseur: Zinc	Arandela distanciadora: Zinc
Pinza: Acciaio SUS 301	Lock claws: SUS 301 Steel	Bremssattel: Edelstahl SUS 301	Pince: Acier SUS 301	Pinza: Acero SUS 301
Anello raccordo: Resina acetilica	Coupling ring: Acetal resin	Mitnehmer-ring: Acetalharz	Bague d'entraînement: Résine acétale	Anillo de conexión: Resina acetal
Guarnizione: NBR esente da silicone	Packing: NBR silicon free	Dichtung: NBR Silikonfrei	Joints: NBS sans silicone	Sello: NBR sin silicona
O-Ring: NBR esente da silicone	O-Ring: NBR silicon free	O-Ringe: NBR Silikonfrei	O-ring: NBS sans silicone	Junta tórica: NBR sin silicona
Attacco girevole: Ottone nichelato CW614N	Rotating body: Nickel plated brass CW614N	Schwenk-verbinding: vernickelt Messing CW614N	Connexion pivotante: Laiton nickelé CW614N	Conexión giratoria: Latón niquelado CW614N

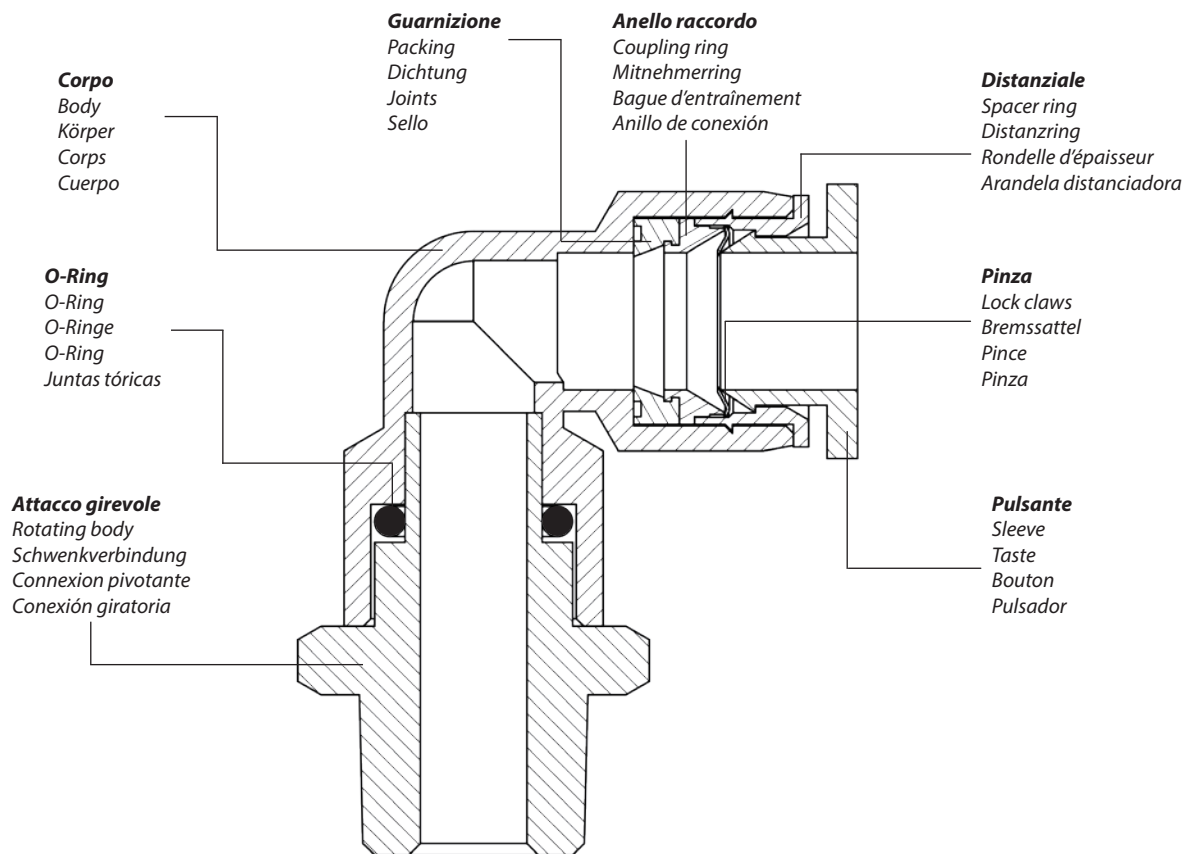

 Pressione e temperatura	 Pressure and Temperature	 Druck und Temperatur	 Pression et Température	 Presión y Temperatura
Tubo: Ø4 - Ø16 mm Pressione (temperatura di utilizzo 20°C): 10 Bar (150 PSI)	Tube: Ø4 - Ø16 mm Pressure (working temperature 20°C): 10 Bar (150 PSI)	Schlauch: Ø4 - Ø16 mm Druck (Betriebstemperatur von 20°C): 10 Bar (150 PSI)	Tuyau: Ø4 - Ø16 mm Pression (température d'utilise de 20°C): 10 bar (150 PSI)	Tubo: Ø4 - Ø16 mm Presión (temperatura de funcionamiento 20 °C): 10 Bar (150 PSI)
Temperatura: -10°C / +60°C	Temperature: +14°F / +140°F	Temperatur: -10°C / +60°C	Température: -10°C / +60°C	Temperatura: -10°C / +60°C

Nota

La pressione è inversamente proporzionale alla temperatura. Più aumenta la temperatura più bassa deve essere la pressione impiegata.

Remarque

La pression est inversement proportionnelle à la température. Plus la température est élevée, plus la pression doit être basse.

Note

The pressure is inversely proportional to the temperature. The higher the temperature the lower the pressure must be.

Nota

La presión es inversamente proporcional a la temperatura. Cuanto más alta sea la temperatura, más baja debe ser la presión.

Hinweis

Der Druck ist umgekehrt proportional zur Temperatur. Je höher die Temperatur, desto niedriger muss der Druck sein.

Tubi consigliati

1)Poliuretano - 2)Poliammide - 3)Polietilene - 4)Nylon

Tuyaux recommandés

1)Polyuréthane 2) Polyamide 3) Polyéthylène 4) Nylon

Recommended tubes

1)Polyurethane - 2)Polyamide - 3)Polyethylen - 4)Nylon

Tubos recomendados

1) Poliuretano - 2) Poliamida - 3) Polietileno - 4) Nylon

Rohrempfehlungen

1)Polyurethan - 2)Polyamid - 3)Polyethylen - 4)Nylon

Fluido

Aria compressa (altri fluidi a richiesta)

Fluide

Aire comprimé (autres fluides sur demande)

Fluid





Compressed air (other fluids on request)

Fluido

Aire comprimido (otros fluidos a petición)

Fluid

Druckluft (andere Medien auf Anfrage)

 Filettatura	 Thread types	 Gewinde	 Filetage	 Roscado
BSPP cilindrica UNI-ISO228 - ISO16030 con O-Ring	BSPP parallel UNI-ISO228 - ISO16030 with O-ring	BSPP zylindrisch UNI-ISO228 - ISO16030 mit O-Ringen	BSPP cylindrique UNI-ISO228 - ISO 16030 avec O-ring	BSPP cilíndrico UNI-ISO 228 - ISO 16030 con junta tórica
BSPT conica UNI-ISO 7 teflonata	BSPT taper UNI-ISO 7 with teflon	BSPT konische UNI-ISO 7 mit Teflon	BSPT conique UNI-ISO7 teflonée	Teflón con recubrimiento BSPT UNI-ISO 7
Metrica ISO/R 262	Metric ISO/R 262	Metrische ISO/R 262	Métrique ISO/R 262	ISO/R 262 métrica

Diametri e filetti

Diametri da 4 mm a 16 mm - Filettature da M5 a 1/2"

Diamètres et filets

Diamètres de 4 mm à 16 mm - Filetages de M5 à 1/2"

Threads and diameters

Diameters from 4 mm to 16 mm - Threads from M5 to 1/2"

Diámetros y roscas

Diámetros de 4 mm a 16 mm - Roscas de M5 a 1/2"

Durchmesser und Gewinde

Durchmesser von 4 mm bis 16 mm - Gewinde von M5 bis 1/2"

Coppia di serraggio

Couple de serrage

Coppia consigliata Nm

Recommended torque Nm

Empfohlenes Drehmoment Nm

Couple de serrage Nm

Par aconsejado Nm

Torque specifications

Par de apriete

0.8 Nm	M5
3 Nm	1/8"
9 Nm	1/4"
10 Nm	3/8"
12 Nm	1/2"

Angaben Drehmoment

Misura

Measure

Grösse

Dimensions

Medida

RP 51K

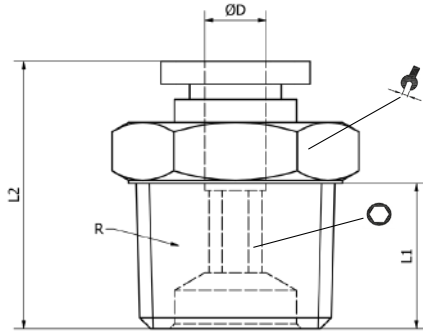

Dritto maschio conico BSPT

Male straight taper BSPT

Gerade Einschraubverschraubung konisches Gewinde

Raccord droit male BSPT conique

Racor recto macho cónico BSPT

CODICE/CODE	ØD	R"	L1	L2			PEZZI/PIECES
RP51K1804	4	R1/8	7,5	20	3	10	10
RP51K1404	4	R1/4	9,5	18	3	14	10
RP51K3804	4	R3/8	10,5	19	3	17	10
RP51K1806	6	R1/8	7,5	20,5	4	12	10
RP51K1406	6	R1/4	9,5	22,5	4	14	10
RP51K3806	6	R3/8	10,5	20,5	4	17	10
RP51K1206	6	R1/2	13,5	24,5	4	21	10
RP51K1808	8	R1/8	7,5	25,5	5	14	10
RP51K1408	8	R1/4	9,5	24,5	5	14	10
RP51K3808	8	R3/8	10,5	21,5	6	17	10
RP51K1208	8	R1/2	13,5	25,5	6	21	10
RP51K1810	10	R1/8	7,5	29,5	5	17	10
RP51K1410	10	R1/4	9,5	31	6	17	10
RP51K3810	10	R3/8	10,5	28,5	8	17	10
RP51K1210	10	R1/2	13,5	26,5	8	21	10
RP51K1812	12	R1/8	7,5	30	5	21	10
RP51K1412	12	R1/4	9,5	30	6	21	10
RP51K3812	12	R3/8	10,5	29	8	21	10
RP51K1212	12	R1/2	13,5	32,5	8	21	10
RP51K3814	14	R3/8	10,5	34	8	22	10
RP51K1214	14	R1/2	13,5	33	10	22	10
RP51K3815	15	R3/8	10,5	37	8	24	10
RP51K1215	15	R1/2	13,5	35	10	24	10
RP51K3816	16	R3/8	10,5	37,5	8	24	10
RP51K1216	16	R1/2	13,5	39,5	10	24	10

RP 51TK

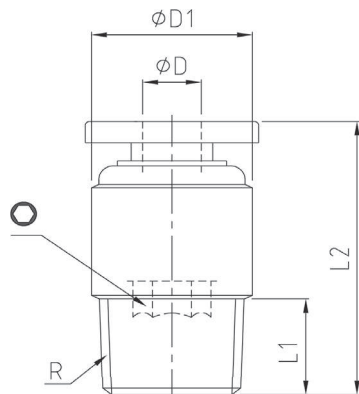

Dritto tondo maschio conico BSPT

Round male straight taper BSPT

Einschraubverschraubung, konisches Gewinde

Raccord droit ronde male BSPT conique

Racor recto ronda macho cónico BSPT

CODICE/CODE	ØD	R"	L1	L2	ØD1		PEZZI/PIECES
RP51TK1804	4	R1/8	7,5	20	10	3	10
RP51TK1404	4	R1/4	9,5	18	14	3	10
RP51TK1806	6	R1/8	7,5	20,5	12	4	10
RP51TK1406	6	R1/4	9,5	22,5	14	4	10
RP51TK3806	6	R3/8	10,5	20,5	17	4	10
RP51TK1808	8	R1/8	7,5	25,5	14	5	10
RP51TK1408	8	R1/4	9,5	24,5	14	5	10
RP51TK3808	8	R3/8	10,5	21,5	17	6	10
RP51TK1208	8	R1/2	13,5	25,5	21	6	10
RP51TK1810	10	R1/8	7,5	29,5	17	5	10
RP51TK1410	10	R1/4	9,5	31	17	6	10
RP51TK3810	10	R3/8	10,5	28,5	17	8	10
RP51TK1210	10	R1/2	13,5	26,5	21	8	10
RP51TK1812	12	R1/8	7,5	31	21	5	10
RP51TK1412	12	R1/4	9,5	33	21	6	10
RP51TK3812	12	R3/8	10,5	30	21	8	10
RP51TK1212	12	R1/2	13,5	32,5	21	8	10

RP 51

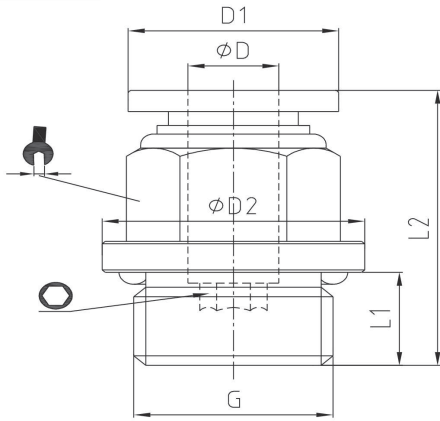

Dritto maschio cilindrico BSPP-metrico

Male straight parallel BSPP-metric

Gerade Einschrauverschraubung zylindrisches - metrisches Gewinde

Raccord droit mâle, cylindrique BSPP - métrique

Racor recto macho cilíndrico con tórica BSPP - métrico

CODICE/CODE	ØD	G"	D1	ØD2	L1	L2		PEZZI/PIECES
RP51M504	4	M5	10	8	3,5	20,3	2	10
RP51M604	4	M6	10	9	4	20,8	2	10
RP511804	4	G1/8	12	14	5,5	19,5	3	10
RP511404	4	G1/4	12	17	7,5	18,6	3	10
RP513804	4	G3/8	12	20	7,5	19,6	3	10
RP51M506	6	M5	12	8	3,5	21	2	12
RP51M606	6	M6	12	9	4	21	2	12
RP511806	6	G1/8	14	14	5,5	22	4	12
RP511406	6	G1/4	14	17	7,5	22,5	4	12
RP513806	6	G3/8	14	20	7,5	20,3	4	12
RP511206	6	G1/2	14	24	10	23	4	12
RP511808	8	G1/8	16	14	5,5	25	4	14
RP511408	8	G1/4	16	17	7,5	24	5	14
RP513808	8	G3/8	16	20	7,5	20,5	6	14
RP511208	8	G1/2	16	24	10	24	6	14
RP511810	10	G1/8	19,5	14	5,5	29	4	17
RP511410	10	G1/4	19,5	17	7,5	30,5	6	17
RP513810	10	G3/8	19,5	20	7,5	27	8	17
RP511210	10	G1/2	19,5	24	10	30	8	17
RP511812	12	G1/8	23	14	5,5	30	4	21
RP511412	12	G1/4	23	17	7,5	33	6	21
RP513812	12	G3/8	23	20	7,5	28	8	21
RP511212	12	G1/2	23	24	10	30,5	8	21
RP513814	14	G3/8	23	22	7,5	32,5	8	22
RP511214	14	G1/2	23	24	10	30	10	24
RP513815	15	G3/8	27	24	7,5	34,5	8	24
RP511215	15	G1/2	27	24	10	31,5	10	24
RP513816	16	G3/8	27	20	7,5	35	8	24
RP511216	16	G1/2	27	24	10	37	10	24

RP 52

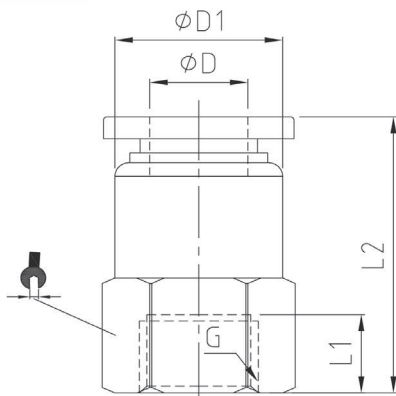

Dritto femmina

Straight female

Gerade Innengewinde

Raccord droit, taraude

Racor recto hembra

CODICE/CODE	ØD	G"	L1	L2	ØD1		PEZZI/PIECES
RP52M504	4	M5	5,5	21	10	10	10
RP52M604	4	M6	6	21,5	10	10	10
RP521804	4	G1/8	8,5	24	10	14	10
RP521404	4	G1/4	11	26,5	10	17	10
RP52M506	6	M5	5,5	21,5	12	12	10
RP52M606	6	M6	6	22	12	12	10
RP521806	6	G1/8	8,5	24,5	12	14	10
RP521406	6	G1/4	11	27	12	17	10
RP523806	6	G3/8	12	28	12	21	10
RP521808	8	G1/8	8,5	26	14	14	10
RP521408	8	G1/4	11	28,5	14	17	10
RP523808	8	G3/8	12	29,5	14	21	10
RP521208	8	G1/2	14	31,5	14	24	10
RP521810	10	G1/8	8,5	29,5	17	17	10
RP521410	10	G1/4	11	32,7	17	17	10
RP523810	10	G3/8	12	33	17	21	10
RP521210	10	G1/2	14	35,7	17	24	10
RP521412	12	G1/4	11	33,5	20	21	10
RP523812	12	G3/8	12	34,5	20	21	10
RP521212	12	G1/2	14	36,5	20	24	10

RP 53

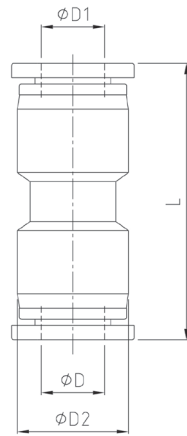

Diritto intermedio

- Straight intermediate
- Gerader Verbinder
- Raccord union double
- Racor recto intermedio

CODICE/CODE	ØD	ØD1	ØD2	L	PEZZI/PIECES
RP530004	4	4	11,5	34	10
RP530006	6	6	13,5	35,5	10
RP530008	8	8	15	38,5	10
RP530010	10	10	19	48	10
RP530012	12	12	21,5	49	10
RP530014	14	14	23,5	50	10
RP530015	15	15	26,5	66	10
RP530016	16	16	26,5	66	10
RP530604	6	4	13,5	35,5	10
RP530804	8	4	15	38,5	10
RP530806	8	6	15	38,5	10
RP531006	10	6	19	46	10
RP531008	10	8	19	47	10
RP531208	12	8	21,5	48	10
RP531210	12	10	21,5	49	10

RP 54

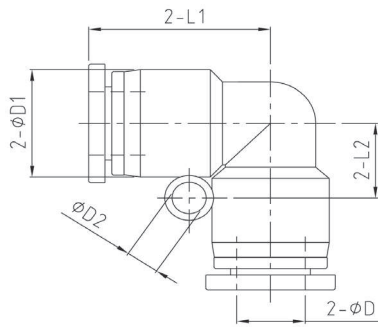

L intermedio

- L intermediate
- Winkelverbinde
- Raccord equerre
- Racor a L intermedio

CODICE/CODE	ØD	ØD1	ØD2	L1	L2	PEZZI/PIECES
RP540004	4	11,5	3,2	19	7	10
RP540006	6	13,5	3,2	19,2	8	10
RP540008	8	15	3,2	22,5	10	10
RP540010	10	19	4,2	27,8	12	10
RP540012	12	21,5	4,2	29,5	13,5	10
RP540014	14	23,5	-	30,5	-	10
RP540015	15	26,5	-	33	-	10
RP540016	16	26,5	-	33	-	10

RP 55

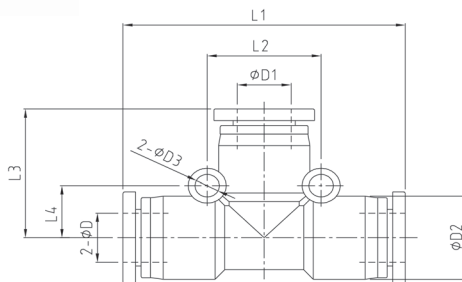

T intermedio

- T intermediate
- T-Verbinder
- Raccord T
- Racor a T intermedio

CODICE/CODE	ØD	ØD1	ØD2	ØD3	L1	L2	L3	L4	PEZZI/PIECES
RP550004	4	4	11,5	3,2	38	14	19	7	10
RP550006	6	6	13,5	3,2	39	16	19,2	8	10
RP550008	8	8	15	3,2	45	18	22,5	9	10
RP550010	10	10	19	4,2	57	24	27,8	12	10
RP550012	12	12	21,5	4,3	59	27	29,5	13,5	10
RP550014	14	14	23,5	-	54	-	30	-	10
RP550015	15	15	26,5	-	66	-	33	-	5
RP550016	16	16	26,5	-	66	-	33	-	5
RP550604	6	4	13,5	3,2	39	16	19,2	8	10
RP550804	8	4	15	3,2	45	18	22,5	9	10
RP550806	8	6	15	3,2	45	18	22,5	9	10
RP551006	10	6	19	4,2	57	24	26,3	12	10
RP551008	10	8	19	4,2	57	24	26,8	12	10
RP551208	12	8	21,5	4,3	59	27	28,5	13,5	10
RP551210	12	10	21,5	4,3	59	27	29,5	13,5	10

RP 58

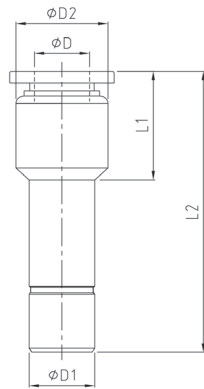

Adattatore riduzione-maggiorazione

- Reducer-increaser plug-in
- Reduzier Stecker
- Réduction encliquetable
- Reducción

CODICE/CODE	ØD	ØD1	ØD2	L1	L2	PEZZI/PIECES
RP580604	4	6	10	16	35	10
RP580804	4	8	10	13	34	10
RP580806	6	8	12	15,5	36	10
RP581006	6	10	12	14	38,5	10
RP581008	8	10	14	17,5	42	10
RP581206	6	12	13,5	13,5	38,5	10
RP581208	8	12	14	17,5	42,5	10
RP581210	10	12	17	21	46	10

RP 59

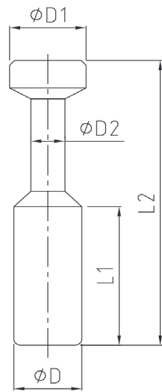

Tappo maschio

- Male plug-in
- Verschluss Stecker
- Bouchon male
- Tapón macho

CODICE/CODE	ØD	ØD1	ØD2	L1	L2	PEZZI/PIECES
RP590004	4	5	3	15	28	10
RP590006	6	7	3	17	33	10
RP590008	8	9	4	18	37	10
RP590010	10	11	5	20,5	42	10
RP590012	12	13	6	23	44	10

RP 60

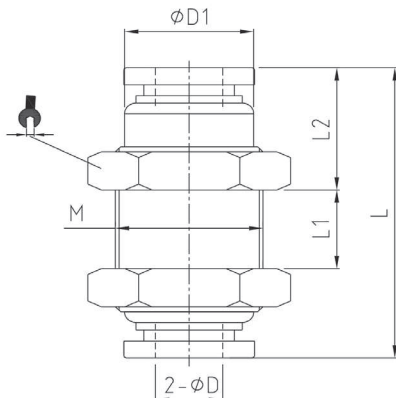

Passalamiera

- Union bulkhead
- Schottverschraubung
- Raccord traversée de cloison
- Racor recto intermedio pasatabiques

CODICE/CODE	ØD	ØD1	M	L	L1	L2		PEZZI/PIECES
RP600004	4	10	M12X1	30,5	9,5	10	14	10
RP600006	6	12	M14X1	31	7,5	10,6	17	10
RP600008	8	14	M16X1	34,5	6,5	12	19	10
RP600010	10	17	M20X1	41,5	11,5	12	24	10
RP600012	12	20	M22X1	44,5	12,5	13,5	26	10

RP 61

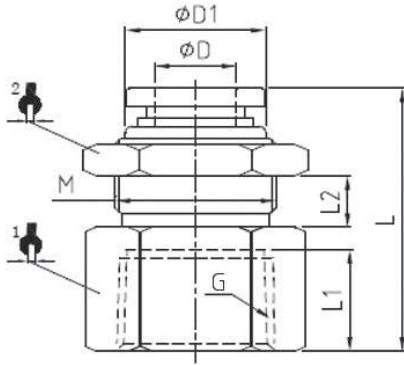

Passalamiera femmina

Female union bulkhead

Schottverschraubung Innengewinde

Raccord droit, taraude

Racor recto hembra

CODICE/CODE	ØD	G"	L	L1	L2	ØD1			M	PEZZI/PIECES
RP611804	4	G1/8	23,5	8,5	5	10	14	14	M12X1	10
RP611404	4	G1/4	26	11	5	10	17	14	M12X1	10
RP611806	6	G1/8	24,8	8,5	7	12	17	17	M14X1	10
RP611406	6	G1/4	29,5	11	7	12	17	17	M14X1	10
RP611808	8	G1/8	26,5	8,5	9	14	19	19	M16X1	10
RP611408	8	G1/4	32	11	9	14	19	19	M16X1	10
RP613808	8	G3/8	34,3	12	9	14	21	19	M16X1	10
RP611410	10	G1/4	32,5	11	9	17	24	24	M20X1	10
RP613810	10	G3/8	34	12	9	17	24	24	M20X1	10
RP611210	10	G1/2	38	14	9	17	24	24	M20X1	10
RP613812	12	G3/8	35	12	9	20	24	26	M22X1	10
RP611212	12	G1/2	37	14	9	20	24	26	M22X1	10

RP 62

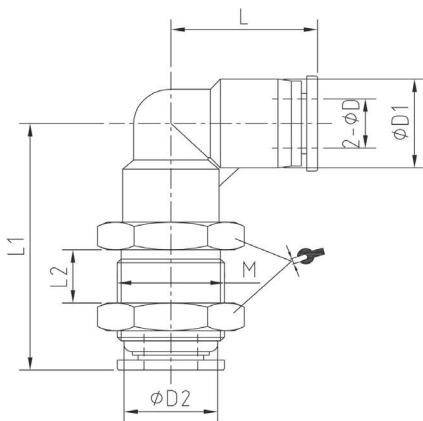

Passalamiera gomito

Elbow union bulkhead

Winkel Schottverschraubung

Cloison coude

Unión mamparo codo

CODICE/CODE	ØD	ØD1	ØD2	L	L1	L2	M		PEZZI/PIECES
RP620004	4	11,5	10	19	31	6	M12X1	14	10
RP620006	6	13,5	12	19,2	34,5	7	M14X1	17	10
RP620008	8	15	14	22,5	41	7,5	M16X1	19	10
RP620010	10	19	17	28,5	47	9,5	M20X1	24	10
RP620012	12	21,5	20	29,5	49	10	M22X1	26	10

RP 65

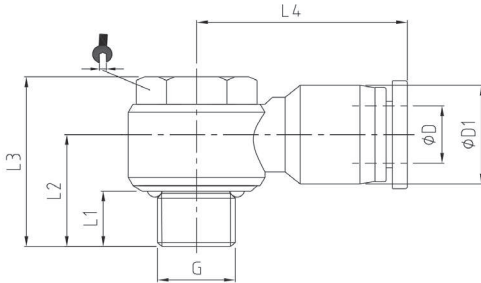

Gomito maschio cilindrico BSPP-metrico

Elbow male parallel BSPP-metric

Winkelverschraubung Drehbar zylindrisches - metrisches Gewinde

Equerre orientable mâle, cylindrique BSPP-métrique

Racor a L orientable macho cilíndrico con tórica BSPP-métrico

CODICE/CODE	ØD	G"	L1	L2	L3	L4	ØD1		PEZZI/PIECES
RP65M504	4	M5	3,5	10,7	17,3	20,5	11,5	8	10
RP651804	4	G1/8	5,5	14,5	23	23,5	11,5	12	10
RP651404	4	G1/4	7,5	17,3	26,3	25,5	11,5	14	10
RP65M506	6	M5	3,5	11,7	17,3	22	13,5	8	10
RP651806	6	G1/8	5,5	14,5	23	23,5	13,5	12	10
RP651406	6	G1/4	7,5	16,7	26,3	25,4	13,5	14	10
RP653806	6	G3/8	7,5	19	32	29,5	13,5	19	10
RP651808	8	G1/8	5,5	15,2	23	26,5	15	12	10
RP651408	8	G1/4	7,5	18	26,3	28,9	15	14	10
RP653808	8	G3/8	7,5	19	32	29,8	15	19	10
RP651208	8	G1/2	10	24,5	39	32,5	15	24	10
RP651410	10	G1/4	7,5	20	26,3	32,6	19	14	10
RP653810	10	G3/8	7,5	21	32	33	19	19	10
RP651210	10	G1/2	10	24,7	39	36	19	24	10
RP653812	12	G3/8	7,5	22,2	32	35,5	21,5	19	10
RP651212	12	G1/2	10	26	39	36,5	21,5	24	10

RP 65F

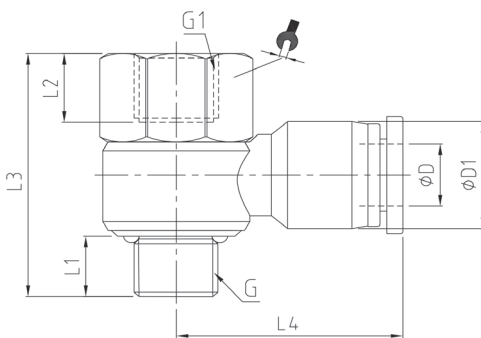

Gomito maschio-femmina cilindrico BSPP-metrico

Elbow male-female parallel BSPP-metric

Winkelverschraubung Auen/Innengewinde zylindrisches-metrisches Gewinde

Equerre orientable mâle-femelle, cylindrique BSPP- métrique

Racor a L orientable macho-hembra cilíndrico con tórica BSPP- métrico

CODICE/CODE	ØD	G"	G1"	L1	L2	L3	L4	ØD1		PEZZI/PIECES
RP65FM504	4	M5	M5	3,5	5,5	20	20,5	11,5	8	10
RP65F1804	4	G1/8	G1/8	5,5	8,5	29	23,5	11,5	14	10
RP65F1404	4	G1/4	G1/4	7,5	11	35	25,5	11,5	17	10
RP65FM506	6	M5	M5	3,5	5,5	20	22	13,5	8	10
RP65F1806	6	G1/8	G1/8	5,5	8,5	29	23,5	13,5	14	10
RP65F1406	6	G1/4	G1/4	7,5	11	35	25,4	13,5	17	10
RP65F1808	8	G1/8	G1/8	5,5	8,5	29	26,5	15	14	10
RP65F1408	8	G1/4	G1/4	7,5	11	35	28,9	15	17	10
RP65F3808	8	G3/8	G3/8	7,5	12	41	29,8	15	21	10
RP65F1410	10	G1/4	G1/4	7,5	11	36	32,6	19	17	10
RP65F3810	10	G3/8	G3/8	7,5	12	41	33	19	21	10
RP65F1210	10	G1/2	G1/2	10	14	47,5	36	19	24	5
RP65F3812	12	G3/8	G3/8	7,5	12	41	35,5	21,5	21	10

RP 70K

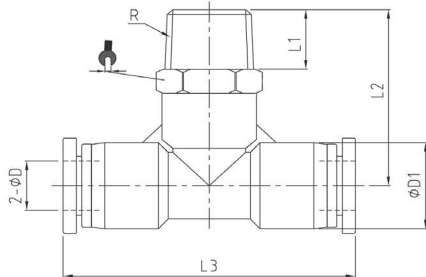



T al centro girevole conico BSPT

 Central T male (rotating body) taper BSPT

 T-Einschraubverschraubung Drehbar konisches Gewinde

 Té orientable à piquage mâle central, conique BSPT

 Racor a T orientable macho central cónico BSPT

CODICE/CODE	∅D	R"	L1	L2	L3	∅D1		PEZZI/PIECES
RP70K1804	4	R1/8	7,5	23,8	38	11,5	10	10
RP70K1806	6	R1/8	7,5	24,2	39	13,5	12	10
RP70K1406	6	R1/4	9,5	26,7	39	13,5	14	10
RP70K1808	8	R1/8	7,5	27,5	45	15	14	10
RP70K1408	8	R1/4	9,5	29,5	45	15	14	10
RP70K3808	8	R3/8	10,5	31	45	15	17	10
RP70K1208	8	R1/2	13,5	34,5	45	15	21	10
RP70K1810	10	R1/8	7,5	32,8	57	19	17	10
RP70K1410	10	R1/4	9,5	34,8	57	19	17	10
RP70K3810	10	R3/8	10,5	35,8	57	19	17	10
RP70K1210	10	R1/2	13,5	39,3	57	19	21	10
RP70K1412	12	R1/4	9,5	36	59	21,5	21	10
RP70K3812	12	R3/8	10,5	37	59	21,5	21	10
RP70K1212	12	R1/2	13,5	40	59	21,5	21	5
RP70K3814	14	R3/8	10,5	41	54	23,5	22	5
RP70K1216	16	R1/2	13,5	47	66	26,5	24	5

RP 70

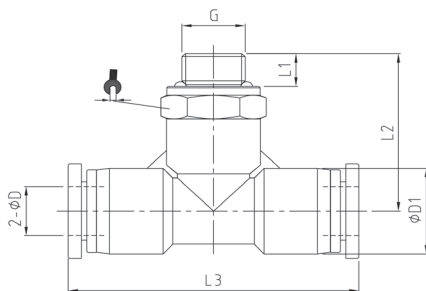

T al centro maschio gir. cilindrico BSPP-metrico

 Central T male (rotating body) parallel BSPP-metric

 T-Einschraubverschraubung Drehbar zylindrisches - metrisches Gewinde

 Té orientable à piquage mâle central, cylindrique BSPP-métrique

 Racor a t orientable macho central cilíndrico con tórica BSPP- métrico

CODICE/CODE	∅D	R"	L1	L2	L3	∅D1		PEZZI/PIECES
RP70M504	4	M5	3,5	21,3	38	11,5	10	10
RP70M604	4	M6	4	21,8	38	11,5	10	10
RP701804	4	G1/8	5,5	24,3	38	11,5	14	10
RP701404	4	G1/4	7,5	26,8	38	11,5	17	10
RP70M506	6	M5	3,5	21,7	39	13,5	12	10
RP70M606	6	M6	4	22,2	39	13,5	12	10
RP701806	6	G1/8	5,5	24,2	39	13,5	14	10
RP701406	6	G1/4	7,5	26,7	39	13,5	17	10
RP703806	6	G3/8	7,5	27,2	39	13,5	20	10
RP701206	6	G1/2	10	29,7	39	13,5	24	10
RP701808	8	G1/8	5,5	27	45	15	14	10
RP701408	8	G1/4	7,5	29,5	45	15	17	10
RP703808	8	G3/8	7,5	30	45	15	20	10
RP701208	8	G1/2	10	32,5	45	15	24	10
RP701810	10	G1/8	5,5	32,3	57	19	17	10
RP701410	10	G1/4	7,5	34,8	57	19	17	10
RP703810	10	G3/8	7,5	34,8	57	19	20	10
RP701210	10	G1/2	10	38,3	57	19	24	10
RP701412	12	G1/4	7,5	36	59	21,5	21	10
RP703812	12	G3/8	7,5	36	59	21,5	21	10
RP701212	12	G1/2	10	39	59	21,5	24	5
RP703814	14	G3/8	7,5	39,5	54	23,5	22	5
RP701214	14	G1/2	10	43	54	23,5	24	5
RP703816	16	G3/8	7,5	42,5	66	26,5	24	5
RP701216	16	G1/2	10	44,5	66	26,5	24	5

RP 71K

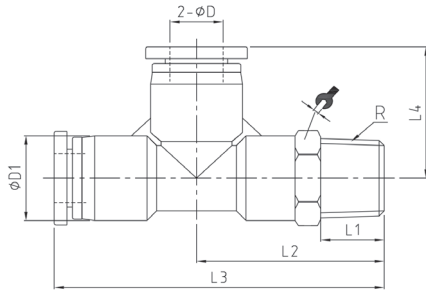

T laterale girevole conico BSPT

Lateral T male (rotating body) taper BSPT

T-Verschraubung Drehbar konisches Gewinde

Té orientable à piquage latéral, conique BSPT

Racor a T orientable macho lateral cónico BSPT

CODICE/CODE	ØD	R"	L1	L2	L3	L4	ØD1		PEZZI/PIECES
RP71K1804	4	R1/8	7,5	23,8	42,8	19	11,5	10	10
RP71K1806	6	R1/8	7,5	24,2	43,4	19,2	13,5	12	10
RP71K1406	6	R1/4	9,5	26,7	46	19,2	13,5	14	10
RP71K1808	8	R1/8	7,5	27,5	50	22,5	15	14	10
RP71K1408	8	R1/4	9,5	29,5	52	22,5	15	14	10
RP71K3808	8	R3/8	10,5	31	53,5	22,5	15	17	10
RP71K1410	10	R1/4	9,5	35	63,5	27,8	19	17	10
RP71K3812	12	R3/8	10,5	37	66,5	29,5	21,5	21	10

RP 71

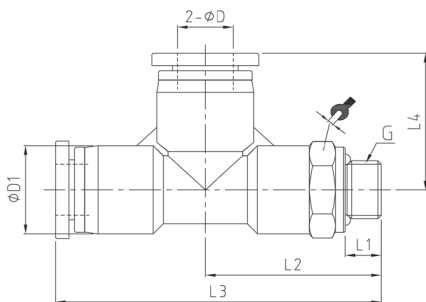

T laterale maschio gir. cilindrico BSPP-metrico

Lateral T male (rotating body) parallel BSPP-metric

T-Verschraubung Drehbar zylindrisches - metrisches Gewinde

Té orientable à piquage latéral, cylindrique BSPP-métrique

Racor a T orientable macho lateral cilíndrico con tórica BSPP- métrico

CODICE/CODE	ØD	G"	L1	L2	L3	L4	ØD1		PEZZI/PIECES
RP71M504	4	M5	3,5	21,3	40,3	19	11,5	10	10
RP711804	4	G1/8	5,5	24,3	43,3	19	11,5	14	10
RP71M506	6	M5	3,5	21,7	40,9	19,2	13,5	12	10
RP711806	6	G1/8	5,5	24,2	43,4	19,2	13,5	14	10
RP711406	6	G1/4	7,5	26,7	46	19,2	13,5	17	10
RP711808	8	G1/8	5,5	27	49,5	22,5	15	14	10
RP711408	8	G1/4	7,5	29,5	52	22,5	15	17	10
RP713808	8	G3/8	7,5	30	52,5	22,5	15	20	10
RP711410	10	G1/4	7,5	35	63,5	27,8	19	17	10
RP713810	10	G3/8	7,5	35	63,5	27,8	19	20	10
RP713812	12	G3/8	7,5	36	65,5	29,5	21,5	21	10
RP711212	12	G1/2	10	39	68,5	29,5	21,5	24	5

RP 72K

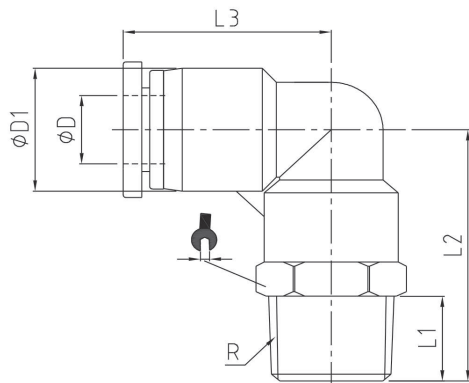

Gomito maschio girevole conico BSPT

Elbow male (rotating body) taper BSPT

Winkelverschraubung Drehbar konisches Gewinde

Equerre orientable mâle, conique BSPT

Racor a L orientable macho cónico BSPT

CODICE/CODE	ØD	R"	L1	L2	L3	ØD1		PEZZI/PIECES
RP72K1804	4	R1/8	7,5	20,5	19	11,5	10	10
RP72K1404	4	R1/4	9,5	20	19	11,5	14	10
RP72K3804	4	R3/8	10,5	21	19	11,5	17	10
RP72K1806	6	R1/8	7,5	21,5	19,2	13,5	10	10
RP72K1406	6	R1/4	9,5	21	19,2	13,5	14	10
RP72K3806	6	R3/8	10,5	22	19,2	13,5	17	10
RP72K1206	6	R1/2	13,5	25,5	19,2	13,5	21	10
RP72K1808	8	R1/8	7,5	22,2	22,5	15	12	10
RP72K1408	8	R1/4	9,5	21,7	22,5	15	14	10
RP72K3808	8	R3/8	10,5	22,7	22,5	15	17	10
RP72K1208	8	R1/2	13,5	26,2	22,5	15	21	10
RP72K1810	10	R1/8	7,5	26,9	27,8	19	14	10
RP72K1410	10	R1/4	9,5	28,4	27,8	19	14	10
RP72K3810	10	R3/8	10,5	24,7	27,8	19	17	10
RP72K1210	10	R1/2	13,5	28,2	27,8	19	21	10
RP72K1812	12	R1/8	7,5	28,2	29,5	21,5	15	10
RP72K1412	12	R1/4	9,5	29,7	29,5	21,5	15	10
RP72K3812	12	R3/8	10,5	26	29,5	21,5	17	10
RP72K1212	12	R1/2	13,5	29,5	29,5	21,5	21	10
RP72K3814	14	R3/8	10,5	34	29,5	23,5	20	10
RP72K1214	14	R1/2	13,5	33	29,5	23,5	20	10
RP72K1215	15	R1/2	13,5	43,5	33	26,5	24	5
RP72K3816	16	R3/8	10,5	44	33	26,5	24	5
RP72K1216	16	R1/2	13,5	47	33	26,5	24	5

RP 72

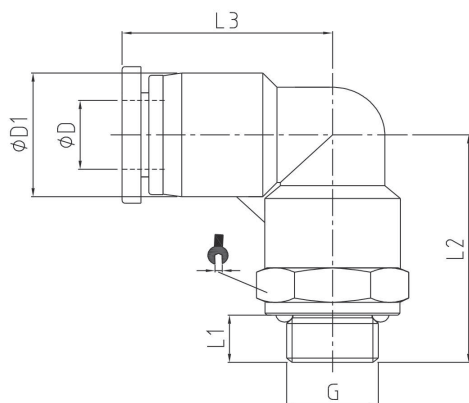

Gomito maschio girevole cilindrico BSPP-metrico

Elbow male (rotating body) parallel BSPP-metric

Winkelverschraubung Drehbar zylindrisches - metrisches Gewinde

Equerre orientable mâle, cylindrique BSPP-métrique

Racor a L orientable macho cilíndrico con tórica BSPP- métrico

CODICE/CODE	ØD	G"	L1	L2	L3	ØD1		PEZZI/PIECES
RP72M504	4	M5	3,5	20	19	11,5	10	10
RP72M604	4	M6	4	20,5	19	11,5	10	10
RP721804	4	G1/8	5,5	22	19	11,5	14	10
RP721404	4	G1/4	7,5	19,5	19	11,5	17	10
RP723804	4	G3/8	7,5	20	19	11,5	20	10
RP72M506	6	M5	3,5	21	19,2	13,5	10	10
RP72M606	6	M6	4	21,5	19,2	13,5	10	10
RP721806	6	G1/8	5,5	23	19,2	13,5	14	10
RP721406	6	G1/4	7,5	20,5	19,2	13,5	17	10
RP723806	6	G3/8	7,5	21	19,2	13,5	20	10
RP721206	6	G1/2	10	23,5	19,2	13,5	24	10
RP721808	8	G1/8	5,5	23,7	22,5	15	14	10
RP721408	8	G1/4	7,5	21,2	22,5	15	17	10
RP723808	8	G3/8	7,5	21,7	22,5	15	20	10
RP721208	8	G1/2	10	24,2	22,5	15	24	10
RP721810	10	G1/8	5,5	26	27,8	19	14	10
RP721410	10	G1/4	7,5	28	27,8	19	17	10
RP723810	10	G3/8	7,5	23,7	27,8	19	20	10
RP721210	10	G1/2	10	26,2	27,8	19	24	10
RP721812	12	G1/8	5,5	27,2	29,5	21,5	15	10
RP721412	12	G1/4	7,5	29,2	29,5	21,5	17	10
RP723812	12	G3/8	7,5	25	29,5	21,5	20	10
RP721212	12	G1/2	10	27,5	29,5	21,5	24	10
RP723814	14	G3/8	7,5	32	29,5	23,5	20	10
RP721214	14	G1/2	10	42,5	30,5	23,5	24	10
RP721215	15	G1/2	10	44,5	33	26,5	24	5

RP 72KP

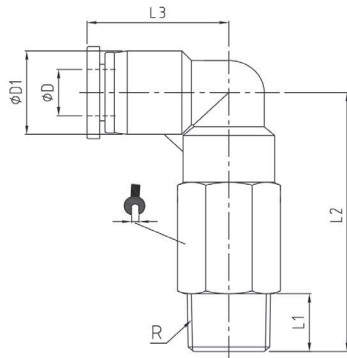

Gomito maschio girevole lungo conico BSPT

Elbow male (rotating body) taper BSPT

Winkelverschraubung Lang Drehbar Kunststoff konisches Gewinde

Equerre prolongée mâle orientable conique BSPT

Racor a L orientable prolongado macho cónico BSPT

CODICE/CODE	ØD	R"	L1	L2	L3	ØD1		PEZZI/PIECES
RP72KP1804	4	R1/8	7,5	35,8	19	11,5	10	10
RP72KP1806	6	R1/8	7,5	38,2	19,2	13,5	12	10
RP72KP1406	6	R1/4	9,5	40,7	19,2	13,5	14	10
RP72KP1808	8	R1/8	7,5	42,8	22,5	15	14	10
RP72KP1408	8	R1/4	9,5	44,8	22,5	15	14	10
RP72KP1410	10	R1/4	9,5	54,3	27,8	19	17	10

RP 72P

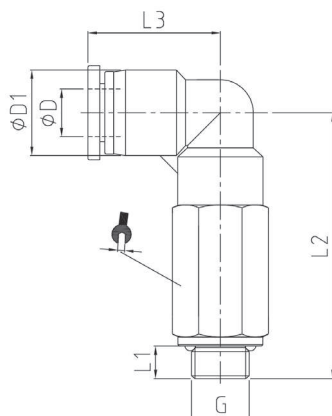

Gomito maschio gir. lungo cilindrico BSPP-metrico

Elbow male (rotating body) parallel BSPP-metric

Winkelverschraubung Lang Drehbar zylindrisches - metrisches Gewinde

Equerre prolongée mâle orientable cylindrique BSPP-métrique

Racor a L orientable prolongado macho cil. con torca BSPP-métrico

CODICE/CODE	ØD	G"	L1	L2	L3	ØD1		PEZZI/PIECES
RP72PM504	4	M5	3,5	33,3	19	11,5	10	10
RP72P1804	4	G1/8	5,5	36,3	19	11,5	14	10
RP72P1404	4	G1/4	7,5	38,3	19	11,5	17	10
RP72PM506	6	M5	3,5	35	19,2	13,5	12	10
RP72PM606	6	M6	4	35,5	19,2	13,5	12	10
RP72P1806	6	G1/8	5,5	37,7	19,2	13,5	14	10
RP72P1406	6	G1/4	7,5	40,2	19,2	13,5	17	10
RP72P3806	6	G3/8	7,5	41,7	19,2	13,5	20	10
RP72P1808	8	G1/8	5,5	42,3	22,5	15	14	10
RP72P1408	8	G1/4	7,5	44,3	22,5	15	17	10
RP72P3808	8	G3/8	7,5	46	22,5	15	20	10
RP72P1810	10	G1/8	5,5	53,8	27,8	19	17	10
RP72P1410	10	G1/4	7,5	54,3	27,8	19	17	10
RP72P3810	10	G3/8	7,5	54,3	27,8	19	20	10
RP72P1210	10	G1/2	10	57,8	27,8	19	24	10
RP72P1412	12	G1/4	7,5	59	29,5	21,5	21	10
RP72P3812	12	G3/8	7,5	59,5	29,5	21,5	21	10
RP72P1212	12	G1/2	10	62,5	29,5	21,5	24	10

RP 72F

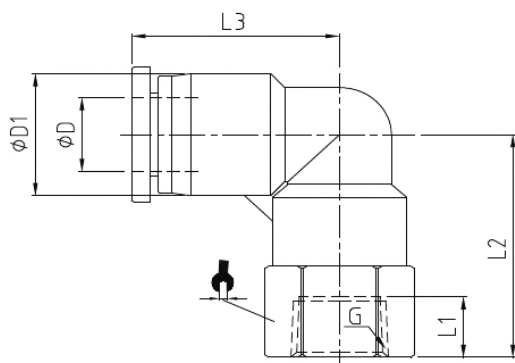

- Gomito femmina girevole cilindrico BSPP-metrico**
- Elbow female (rotating body) parallel BSPP-metric
- Winkelverschraubung Innengewinde zylindrisches - metrisches Gewinde
- Equerre orientable femelle, cylindrique BSPP-métrique
- Racor a L orientable hembra cilíndrico BSPP- métrico

CODICE/CODE	ØD	G"	L1	L2	L3	ØD1		PEZZI/PIECES
RP72FM604	4	M6	6	20	19	11,5	10	10
RP72F1804	4	G1/8	8,5	23,3	19	11,5	14	10
RP72F1404	4	G1/4	11	25,8	19	11,5	17	10
RP72FM506	6	M5	5,5	19,2	19,2	13,5	12	10
RP72FM606	6	M6	6	19,7	19,2	13,5	12	10
RP72F1806	6	G1/8	8,5	22,7	19,2	13,5	14	10
RP72F1406	6	G1/4	11	25,7	19,2	13,5	17	10
RP72F3806	6	G3/8	12	27,2	19,2	13,5	21	10
RP72F1808	8	G1/8	8,5	25	22,5	15	14	10
RP72F1408	8	G1/4	11	28,5	22,5	15	17	10
RP72F3808	8	G3/8	12	30	22,5	15	21	10
RP72F1410	10	G1/4	11	32,3	27,8	19	17	10
RP72F3810	10	G3/8	12	33,8	27,8	19	21	10
RP72F1210	10	G1/2	14	36,8	27,8	19	24	10
RP72F1412	12	G1/4	11	34,5	29,5	21,5	21	10
RP72F3812	12	G3/8	12	35,5	29,5	21,5	21	10
RP72F1212	12	G1/2	14	38	29,5	21,5	24	10

RP 45

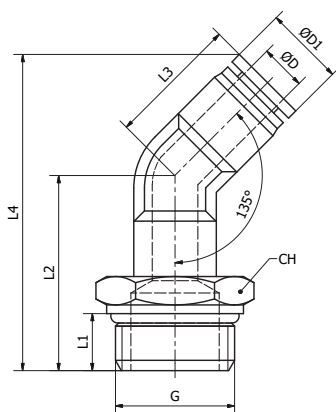

- Gomito maschio 45° gir. cilindrico BSPP-metrico**
- Elbow male 45° (rotating body) parallel BSPP-metric
- Winkelverschraubung 45° Drehbar zylindrisches - metrisches Gewinde
- Equerre à 45° orientable mâle, cylindrique BSPP-métrique
- Racor a 45° orientable macho cilíndrico con torica BSPP- métrico

CODICE/CODE	ØD	G"	L1	L2	L3	L4	ØD1		PEZZI/PIECES
RP451806	6	G1/8	5,5	25,5	19,2	43,5	13,3	14	10
RP451406	6	G1/4	7,5	28	19,2	46	13,3	17	10
RP451808	8	G1/8	5,5	29	22,5	49,5	14,8	14	10
RP451408	8	G1/4	7,5	31,5	22,5	52	14,8	17	10

RP 73

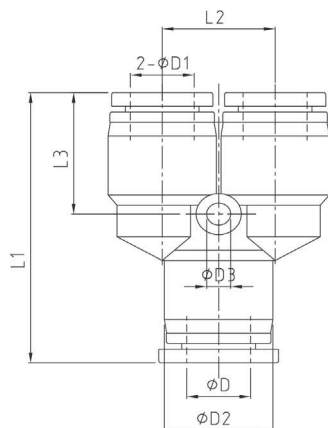



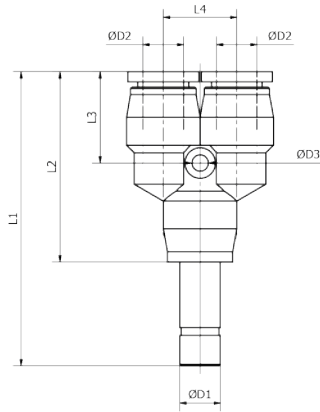

- Y innestabile**
- Y connector
- Y Verteiler
- Raccord y simple
- Racor a y intermedio

CODICE/CODE	ØD	ØD1	ØD2	ØD3	L1	L2	L3	PEZZI/PIECES
RP730004	4	4	11,5	3,2	36,5	11	14,5	10
RP730006	6	6	13,5	3,2	37,5	13	15	10
RP730008	8	8	15	3,2	39,8	15	18	10
RP730010	10	10	19	4,2	50	18	21	10
RP730012	12	12	21,5	4,2	53	21	21,5	10
RP730604	6	4	13,5	3,2	37,5	13	15	10
RP730804	8	4	15	3,2	39,8	15	18	10
RP730806	8	6	15	3,2	39,8	15	18	10
RP731006	10	6	19	4,2	39,8	18	21	10
RP731008	10	8	19	4,2	50	18	21	10
RP731208	12	8	21,5	4,2	53	21	21,5	10
RP731210	12	10	21,5	4,2	53	21	21,5	10

RP 91







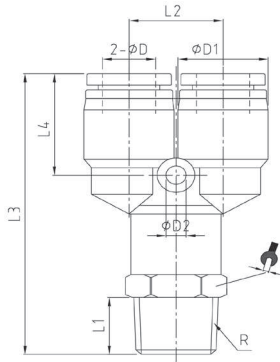

-  **Y pari con codolo**
-  **Y with plug-in**
-  **Y Verteiler**
-  **Raccord y encliquetable**
-  **Racor a y intermedio con adaptador**

CODICE/CODE	ØD	ØD1	ØD2	ØD3	L1	L2	L3	L4	PEZZI/PIECES
RP910004	4	4	11,5	3,2	52,5	33,5	14,5	11	10
RP910006	6	6	13,5	3,2	53,8	34,8	15	13	10
RP910008	8	8	15	3,2	57,8	37,3	18	15	10
RP910604	4	6	11,5	3,2	52,8	33,8	14,5	11	10
RP910806	6	8	13,5	3,2	55,5	35	15	13	10
RP911008	8	10	15	3,2	62	37,3	18	15	10
RP911210	10	12	19	4,2	72,5	46,5	21	18	5

RP 74K







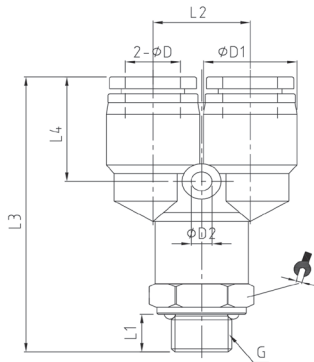

-  **Y maschio girevole conico BSPT**
-  **Y male (rotating body) taper BSPT**
-  **Y Einschraubverschraubung Drehbar konisches Gewinde**
-  **Y simple orientable mâle, conique BSPT**
-  **Racor a y orientable macho cónico BSPT**

CODICE/CODE	ØD	R"	L1	L2	L3	L4	ØD1	ØD2		PEZZI/PIECES
RP74K1804	4	R1/8	7,5	11	42,5	14,5	11,5	3,2	10	10
RP74K1806	6	R1/8	7,5	13	44	15	13,5	3,2	12	10
RP74K1406	6	R1/4	9,5	13	46,5	15	13,5	3,2	14	10
RP74K1808	8	R1/8	7,5	15	46,5	18	15	3,2	14	10
RP74K1408	8	R1/4	9,5	15	48,5	18	15	3,2	14	10
RP74K1410	10	R1/4	9,5	18	58,5	21	19	4,2	17	10
RP74K3810	10	R3/8	10,5	18	59,5	21	19	4,2	17	10
RP74K1210	10	R1/2	13,5	18	63	21	19	4,2	21	10
RP74K1212	12	R1/2	13,5	21	66	21,5	21,5	4,2	21	5

RP 74



-  **Y maschio girevole cilindrico BSPP-metrico**
-  **Y male (rotating body) parallel BSPP-metric**
-  **Y Einschraubverschraubung Drehbar zylindrisches - metrisches Gewinde**
-  **Y simple orientable mâle, cylindrique BSPP-métrique**
-  **Racor a y orientable macho cilíndrico con tórica BSPP- métrico**

CODICE/CODE	ØD	G"	L1	L2	L3	L4	ØD1	ØD2		PEZZI/PIECES
RP74M504	4	M5	3,5	11	40	14,5	11,5	3,2	10	10
RP741804	4	G1/8	5,5	11	43	14,5	11,5	3,2	14	10
RP741404	4	G1/4	7,5	11	45,5	14,5	11,5	3,2	17	10
RP74M506	6	M5	3,5	13	41,5	15	13,5	3,2	12	10
RP741806	6	G1/8	5,5	13	44	15	13,5	3,2	14	10
RP741406	6	G1/4	7,5	13	46,5	15	13,5	3,2	17	10
RP743806	6	G3/8	7,5	13	47	15	13,5	3,2	20	10
RP741206	6	G1/2	10	13	49,5	15	13,5	3,2	24	10
RP741808	8	G1/8	5,5	15	46,3	18	15	3,2	14	10
RP741408	8	G1/4	7,5	15	48,8	18	15	3,2	17	10
RP743808	8	G3/8	7,5	15	49,3	18	15	3,2	20	10
RP741208	8	G1/2	10	15	51,8	18	15	3,2	24	10
RP741810	10	G1/8	5,5	18	56	21	19	4,2	17	10
RP741410	10	G1/4	7,5	18	58,5	21	19	4,2	17	10
RP743810	10	G3/8	7,5	18	58,5	21	19	4,2	20	10
RP741210	10	G1/2	10	18	62	21	19	4,2	24	10
RP741412	12	G1/4	7,5	21	62	21,5	21,5	4,2	21	10
RP743812	12	G3/8	7,5	21	62	21,5	21,5	4,2	21	10
RP741212	12	G1/2	10	21	65	21,5	21,5	4,2	24	5

RP 75

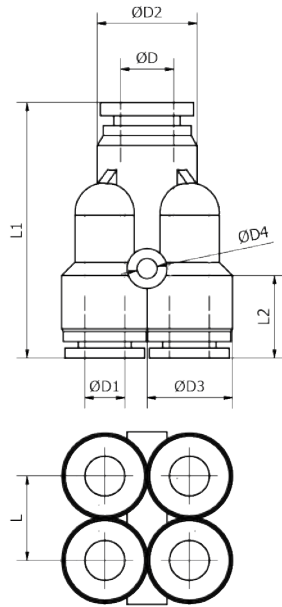

🇮🇹 Doppio Y riduzione

- 🇬🇧 Double Y reducer
- 🇩🇪 Y 4 Ausgänge reduzierte Verteiler
- 🇫🇷 Raccord y double
- 🇪🇸 Racor a y múltiple intermedio

CODICE/CODE	ØD	ØD1	ØD2	ØD3	ØD4	L	L1	L2	PEZZI/PIECES
RP750604	6	4	13,3	11,3	3,2	11	36,5	15	10
RP750806	8	6	14,8	13,3	3,2	13	40	15,5	10

RP 76

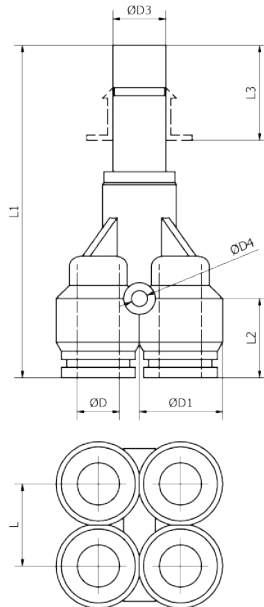

🇮🇹 Doppio Y riduzione con codolo

- 🇬🇧 Double Y reducer with plug-in
- 🇩🇪 Y 4 Ausgänge Verteiler mit innenkonus
- 🇫🇷 Y double orientable
- 🇪🇸 Racor a y doble orientable

CODICE/CODE	ØD3	ØD	ØD1	ØD2	L	L1	L2	L3	PEZZI/PIECES
RP760604	6	4	11,3	3,2	11	53	15	13	10
RP760806	8	6	13,3	3,2	13	58	15,5	14	10
RP761008	10	8	14,8	3,2	15	63	16,5	18	10

RP 83K

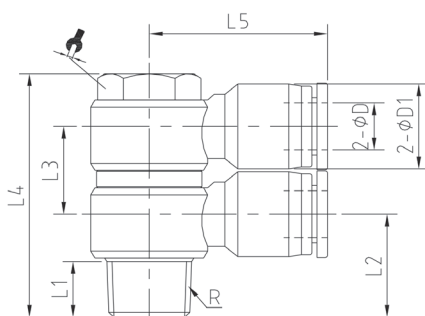

🇮🇹 Doppio L maschio girevole conico BSPT

- 🇬🇧 Double L male (rotating body) taper BSPT
- 🇩🇪 Winkeleinschraubverschraubung 2-Fach Drehbar konisches Gewinde
- 🇫🇷 Double orientable, piquage latéral, conique BSPT
- 🇪🇸 Racor distribuidor doble de reducción orientable macho cónico BSPT

CODICE/CODE	ØD	R"	L1	L2	L3	L4	L5	L6	🔧 PEZZI/PIECES
RP83K1804	4	R1/8	7,5	14	15	38	23,5	11,5	10
RP83K1806	6	R1/8	7,5	14	15	38	23,5	13,5	10
RP83K1406	6	R1/4	9,5	16,5	15	41,5	25,4	13,5	10
RP83K1808	8	R1/8	7,5	14,5	15	38	26,5	15	10
RP83K1408	8	R1/4	9,5	17,5	15	41,5	29	15	10
RP83K1208	8	R1/2	13,5	25,5	21,5	60	32,5	15	5
RP83K1410	10	R1/4	9,5	18,5	21,5	44,8	32,5	19	10
RP83K3810	10	R3/8	10,5	20,5	21,5	53	33	19	10

RP 83

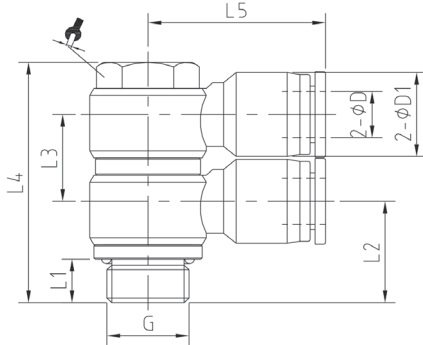

Doppio L maschio girevole cilindrico BSPP

Double L male (rotating body) parallel BSPP

Winkeleinschraubverschraubung 2-Fach Drehbar zylindrisches Gewinde

Double orientable, piquage latéral, cylindrique BSPP

Racor distribuidor doble de reducción orientable macho cilíndrico BSPP

CODICE/CODE	ØD	G"	L1	L2	L3	L4	L5	L6		PEZZI/PIECES
RP831804	4	G1/8	5,5	14	15	38	23,5	11,5	12	10
RP831806	6	G1/8	5,5	14	15	38	23,5	13,5	12	10
RP831406	6	G1/4	7,5	17,3	15	41,5	25,4	13,5	14	10
RP833806	6	G3/8	7,5	19	15,7	49,5	29,5	13,5	19	10
RP831808	8	G1/8	5,5	15	15	38	26,5	15	12	10
RP831408	8	G1/4	7,5	18,3	15	41,5	29	15	14	10
RP833808	8	G3/8	7,5	19	15,7	49,5	30	15	19	10
RP831208	8	G1/2	10	24,5	21,5	57	32,5	15	24	5
RP831410	10	G1/4	7,5	20	21,5	44,8	32,5	19	14	10
RP833810	10	G3/8	7,5	21	21,5	53	33	19	19	10
RP831210	10	G1/2	10	25	21,5	60	36	19	24	10
RP831212	12	G1/2	10	26	21,5	60,5	36,5	21,5	24	5

RP 84K

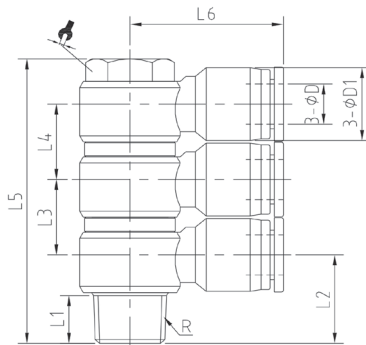

Triplo L maschio girevole conico BSPT

Triple L male (rotating body) taper BSPT

Winkeleinschraubverschraubung 3-Fach Drehbar konisches Gewinde

Triple orientable, piquage latéral, conique BSPT

Racor distribuidor triple de reducción orientable macho cónico BSPT

CODICE/CODE	ØD	R"	L1	L2	L3	L4	L5	L6	ØD1		PEZZI/PIECES
RP84K1804	4	R1/8	7,5	14	15	15	53	23,5	11,5	12	10
RP84K1806	6	R1/8	7,5	14	15	15	53	23,5	13,5	12	10
RP84K1406	6	R1/4	9,5	16,5	15	15	56,5	25,4	13,5	14	10
RP84K1808	8	R1/8	7,5	14,5	15	15	53	26,5	15	12	10
RP84K1408	8	R1/4	9,5	17,5	15	15	56,5	29	15	14	10
RP84K1410	10	R1/4	9,5	18,5	21,5	21,5	69,5	32,5	19	14	10
RP84K3812	12	R3/8	10,5	22	21,5	21,5	78	35,5	21,5	19	10

RP 85

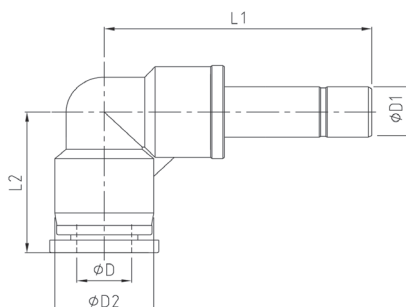

L intermedio con codolo

L intermediate with plug-in

Winkelanschluss





Raccord equerre encliquetable

Racor a L con adaptador

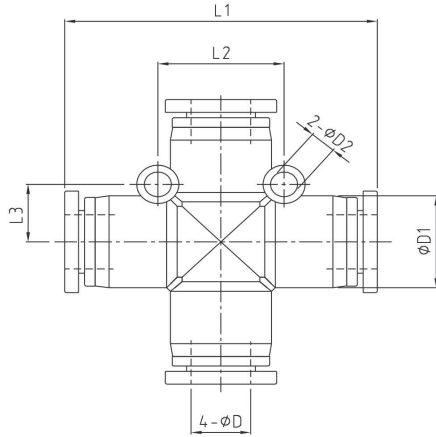
CODICE/CODE	ØD	ØD1	ØD2	L1	L2	PEZZI/PIECES
RP850004	4	4	11,5	33,7	19	10
RP850006	6	6	13,5	34	19,2	10
RP850008	8	8	15	38,5	22,5	10
RP850010	10	10	19	46,8	27,8	10
RP850012	12	12	21,5	49,5	29,5	10
RP850604	4	6	11,5	34	19	10
RP850806	6	8	13,5	35,7	19,2	10
RP851008	8	10	15	42,5	22,5	10
RP851210	10	12	19	48,3	27,8	10

RP 88





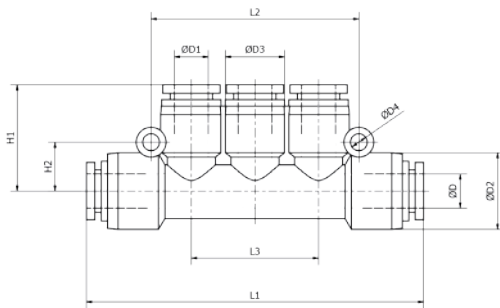

-  **Croce intermedio**
-  **Cross intermediate**
-  **Kreuzverteile**
-  **Croix égale**
-  **Racor a cruz intermedio**

CODICE/CODE	ØD	ØD1	ØD2	L1	L2	L3	PEZZI/PIECES
RP880004	4	11,5	3,2	38	14	7	10
RP880006	6	13,5	3,2	39	16	8	10
RP880008	8	15	3,2	45	18	9	10
RP880010	10	19	4,2	57	24	12	10
RP880012	12	21,5	4,3	59	27	13,5	10

RP 89



-  **T multiplo**
-  **Multi T**
-  **T Mehrfachverteiler**
-  **Multi-tè**
-  **Racor distribuidor múltiple**

CODICE/CODE	ØD	ØD1	ØD2	ØD3	ØD4	L1	L2	L3	H1	H2	PEZZI/PIECES
RP890404	4	4	14,5	13	3,2	57	36	22	19	8	10
RP890606	6	6	14,5	13	3,2	58	36	22	19,5	8	10
RP890808	8	8	19	14,5	4,2	84	61	29	24,5	11,5	10
RP891010	10	10	19	14,5	4,2	87	61	29	26	11,5	5
RP890604	6	4	14,5	13	3,2	58	36	22	19	8	10
RP890804	8	4	18,4	14,5	3,2	62	42	26	20,5	9	10
RP890806	8	6	18,4	14,5	3,2	81	48	29	24,5	9	10
RP891006	10	6	19	14,5	4,2	87	61	29	24,5	11,5	5
RP891008	10	8	19	14,5	4,2	87	61	29	24,5	11,5	5