

# DOSING PUMP

## SPRING SERIES – PS2 – Plunger piston pump

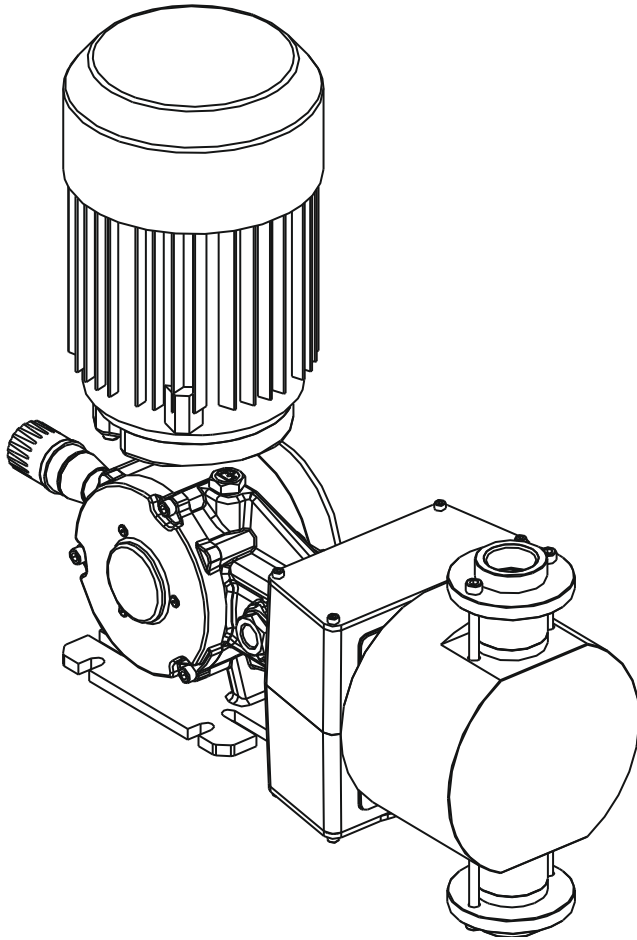

### Technical characteristics

- Flow rates: from 40 to 1000 l/h
- Max Pressure: up to 20 bar (290 psi)
- Motor:
  - 0.25 kW to 0.75 kW - 3 ph (IP55)
  - 0.37 kW to kW – 1.1 kW 1ph (IP55)
- Stroke rate: 58 –116 strokes/minute
- Stroke length: 25 mm
- Piston diameter: from 25 to 89 mm
- Pump head:
  - SS 316 L
  - PVC
- Max. dosing temperature:
  - SS 316 L 90° C
  - PVC 40° C
- Ambient dosing temperature:
  - +5 ÷ +45 °C
- Stacking temperature:
  - -10 ÷ +50 °C

Seko plunger piston pump PS2 Series has a wide range product. PS2 Series performances cover s from 40 to1000 l/h with a back pressure up to 20 bar, having several configurations available for the pump head and power, in order to have the characteristics most suitable for processes where required.

PS2 pump have a spring return mechanism into an aluminum housing.

Each model has 2 values of stroke rate and 25 mm of stroke length, which can be set manually or automatically using a linear actuator which accepts a signal 4 – 20 mA. Moreover they can be supplied with a 3 phases or 1 phase electric motor with protection class IP55.

PS2 Series have the same features than PS1, still change the some hydraulic characteristic due by bigger size of piston, longer stroke length, therefore the flow rate and power.

# DOSING PUMP

## SPRING SERIES – PS2 – Plunger piston pump



### PUMP KEY CODE

Field 1	Field 2	Field 3	Field 4	Field 5	Field 6	Field 7	Field 8	Field 9	Field 10
P	S2	E	038	C	21	U4	0	0	0

Field 1	model	←
Field 2	mechanism family	←
Field 3	stroke length	←
Field 4	piston diameter	←
Field 5	stroke rate	←
Field 6	pump head material	←
Field 7	electric motor type	←
Field 8	stroke regulation	←
Field 9	customization	←
Field 10	optional	←

Field 1	model	<b>P</b>	<b>Plunger Piston</b>
---------	-------	----------	-----------------------

Field 2	mechanism family	<b>S2</b>	<b>Piston</b>
---------	------------------	-----------	---------------

Field 3	stroke length	<b>E</b>	<b>25 [mm]</b>
---------	---------------	----------	----------------

Field 4	piston diameter	<b>025</b>	<b>25 [mm]</b>	<b>054</b>	<b>54 [mm]</b>
		<b>030</b>	<b>30</b>	<b>064</b>	<b>64</b>
		<b>038</b>	<b>38</b>	<b>076</b>	<b>76</b>
		<b>048</b>	<b>48</b>	<b>089</b>	<b>89</b>

Field 5	stroke rate	<b>A</b>	<b>58 [stroke/1']</b>
		<b>C</b>	<b>116</b>

Field 6	pump head material	head	piston	pist. seal	valves	seat valves	O-Ring
	<b>21</b>	SS316	SS316	FPM	SS316	SS316	FPM
	<b>31</b>	PVC	CERAMIC	FPM	CERAMIC	PTFE	FPM on Ø 25 - 30 - 38
	<b>24</b>	SS316	CERAMIC	EPDM	SS316	SS316	EPDM
	<b>32</b>	PVC	CERAMIC	FPM	SS316	SS316	FPM on Ø 25 - 30 - 38
	<b>34</b>	PVC	CERAMIC	EPDM	CERAMIC	PTFE	EPDM on Ø 25 - 30 - 38

Field 7	electric motor type	<b>T4</b>	<b>0,25 kW</b>	<b>(4 poles - 3phases 230-400 Vac 50/60 Hz - size 71-B5)</b>
		<b>U4</b>	<b>0,37 kW</b>	<b>(4 poles - 3phases 230-400 Vac 50/60 Hz - size 71-B5)</b>
		<b>D4</b>	<b>0,55 kW</b>	<b>(4 poles - 3phases 230-400 Vac 50/60 Hz - size 80-B14)</b>
		<b>E4</b>	<b>0,75 kW</b>	<b>(4 poles - 3phases 230-400 Vac 50/60 Hz - size 80-B14)</b>
		<b>Z4</b>	<b>0,37 kW</b>	<b>(4 poles - 1phase 230 Vac 50 Hz - size 71-B5)</b>
		<b>L4</b>	<b>0,55 kW</b>	<b>(4 poles - 1phase 230 Vac 50 Hz - size 80-B14)</b>
		<b>M4</b>	<b>0,75 kW</b>	<b>(4 poles - 1phase 230 Vac 50 Hz - size 80-B14)</b>
		<b>N4</b>	<b>1,1 kW with breaker torque</b>	<b>(4 poles - 1phase 230 Vac 50 Hz - size 71-B14)</b>
		<b>BI</b>	<b>0,25 kW</b>	<b>(4 poles - 3phases 230-400 Vac 50/60 Hz - size 71-B5 - with INVERTER)</b>
		<b>CI</b>	<b>0,37 kW</b>	<b>(4 poles - 3phases 230-400 Vac 50/60 Hz - size 71-B5 - with INVERTER)</b>
		<b>DI</b>	<b>0,55 kW</b>	<b>(4 poles - 3phases 230-400 Vac 50/60 Hz - size 80-B14 - with INVERTER)</b>
		<b>EI</b>	<b>0,75 kW</b>	<b>(4 poles - 3phases 230-400 Vac 50/60 Hz - size 80-B14 - with INVERTER)</b>
		<b>S0</b>	<b>WITHOUT motor</b>	

Field 8	stroke regulation	<b>0</b>	<b>Manual with adjustment knob - STANDARD</b>
		<b>L</b>	<b>Automatic Linear Actuator AKTUA series</b>

Field 9	customization	<b>0</b>	<b>Standard</b>
		<b>H</b>	<b>High Pressure</b>

Field 10	optional	<b>0</b>	<b>Standard</b>
		<b>2</b>	<b>( S0 - WITHOUT motor ) + adapter kit</b>

# DOSING PUMP

## SPRING SERIES – PS2 – Plunger piston pump



### HYDRAULIC CHARACTERISTICS

Pump Model	Piston Diameter [mm]	Stroke/min	Flow rate		Max back pressure				Suction/Discharge Connection		Electric Motor 50 Hz 3 phases [kW]
					bar		p.s.i.				
			l/h	gl/h	SS 316	PVC	SS 316	PVC	SS 316	PVC	
P S 2 E 0 2 5 A	25	58	40	10.57	20	10	290	145	3/8" G F	3/8" G F	0,25 (T4)
P S 2 E 0 2 5 C		116	80	21.13							
P S 2 E 0 3 0 A	30	58	55	14.53	20	10	290	145	3/8" G F	3/8" G F	0,25 (T4)
P S 2 E 0 3 0 C		116	112	29.59							
P S 2 E 0 3 8 A	38	58	90	23.77	20	10*	290	145*	1/2" G F	3/8" G F	0,37 (U4)
P S 2 E 0 3 8 C		116	180	47.55							
P S 2 E 0 4 8 A	48	58	140	36.98	20	10*	290	145*	1/2" G F	1/2" G F	0,55 (D4)
P S 2 E 0 4 8 C		116	284	75.02							
P S 2 E 0 5 4 A	54	58	180	47.55	15	10	217	145	1/2" G F	1/2" G F	0,55 (D4)
P S 2 E 0 5 4 C		116	365	96.42							
P S 2 E 0 6 4 A	64	58	250	66.04	10	10	145	145	3/4" G F	3/4" G F	0,75 (E4)
P S 2 E 0 6 4 C		116	505	133.40							
P S 2 E 0 7 6 A	76	58	365	96.42	7	7	101	101	1" G F	1" G F	0,75 (E4)
P S 2 E 0 7 6 C		116	730	192.85							
P S 2 E 0 8 9 A	89	58	495	130.76	5	5	72.5	72.5	1" G F	1" G F	0,75 (E4)
P S 2 E 0 8 9 C		116	1000	264.17							

\* Available with special reinforced pump head for use with pressure up to 20 bar - 14' Field (Optional) in the Key Code identified by "H"

### DIMENSIONS

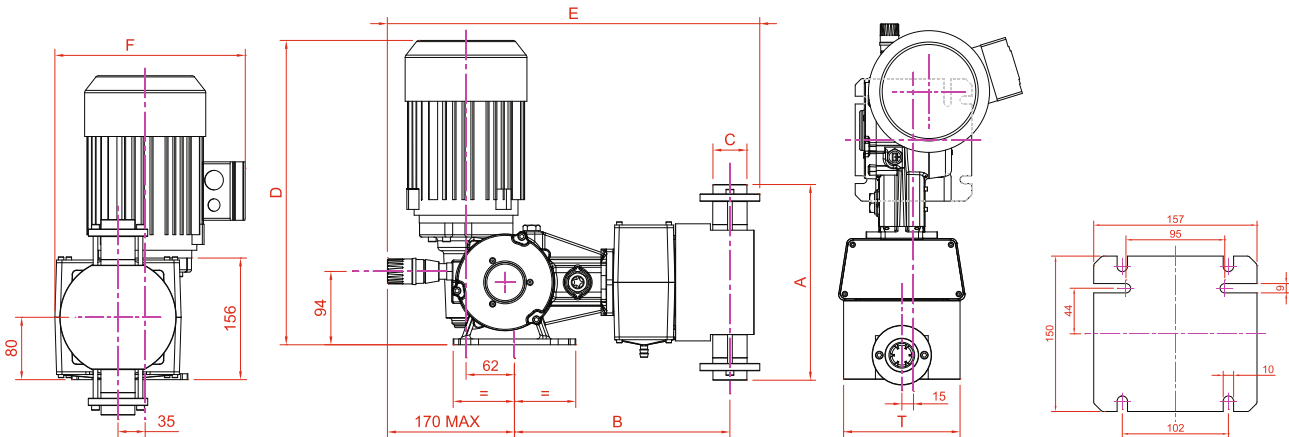

Mat testata Liquid end mat	Diam pistone Plunger diam	A[mm]	B[mm]	C (BSP)	T[mm]	Three phase					Single phase				
						Motore 4P Motor 4P [kW]	Gr. motore Motor Size	D[mm]	E[mm]	F[mm]	Motore 4P Motor 4P [kW]	Gr. motore Motor Size	D[mm]	E[mm]	F[mm]
AISI316 (21)	25	121	258	3/8" f	68	0.25	71 B5	385	421	168	0.37	71 B5	385	421	168
	30	122	258	3/8" f	68	0.25	71 B5	385	421	168	0.37	71 B5	385	421	168
	38	164	268	1/2" f	88,5	0.37	71 B5	385	433	189	0.55	80 B14	398	433	189
	48	164	268	1/2" f	88,5	0.55	80 B14	398	448	189	0.75	80 B14	398	448	189
	54	176	268	1/2" f	108	0.55	80 B14	398	450	208	0.75	80 B14	398	450	208
	64	195	273	3/4" f	103	0.75	80 B14	398	469	203	1,10	80 B14	412	469	203
	76	241	288	1" f	112	0.75	80 B14	398	490	212	1,10	80 B14	412	490	212
89	253	288	1" f	125	0.75	80 B14	398	490	225	1,10	80 B14	412	490	225	
PVC (31)	25	179	258	3/8" f	78	0.25	71 B5	385	431	178	0.37	71 B5	385	431	178
	30	178	258	3/8" f	78	0.25	71 B5	385	431	178	0.37	71 B5	385	431	178
	38	200	268	3/8" f	98	0.37	71 B5	385	445	198	0.55	80 B14	398	445	198
	48	244	268	1/2" f	108	0.55	80 B14	398	461	208	0.75	80 B14	398	461	208
	54	253	268	1/2" f	118	0.55	80 B14	398	461	218	0.75	80 B14	398	461	218
	64	273	273	3/4" f	118	0.75	80 B14	398	471	218	1,10	80 B14	412	471	218
	76	299	288	1" f	148	0.75	80 B14	398	491	248	1,10	80 B14	412	491	248
89	309	288	1" f	158	0.75	80 B14	398	491	258	1,10	80 B14	412	491	258	

# DOSING PUMP

## SPRING SERIES – PS2 – Plunger piston pump

